



GENUINE PRODUCTS

38MT+™ Heavy Duty Gear Reduction Starter

FEATURES & BENEFITS

- **Available* with Integrated Over Crank Protection (IOCP)**, a built-in circuit breaker, protects the starter from thermal damage, automatically resetting at a safe operating temperature while eliminating the need for a wiring harness.
- **38MT+ features an Integral Magnetic Switch (IMS)**. IMS reduces voltage drop and ensures the solenoid receives the maximum available voltage in any starting condition.
- **Electrical soft-start** consistently and accurately engages the pinion with the ring gear providing increased reliability.
- **Warranty:** Non-OCP model: 1 year / unlimited miles
Integrated OCP model: 3 years / unlimited miles (Applicable to U.S. and Canada only)

* Part Number 8201084



COMPETITIVE COMPARISON

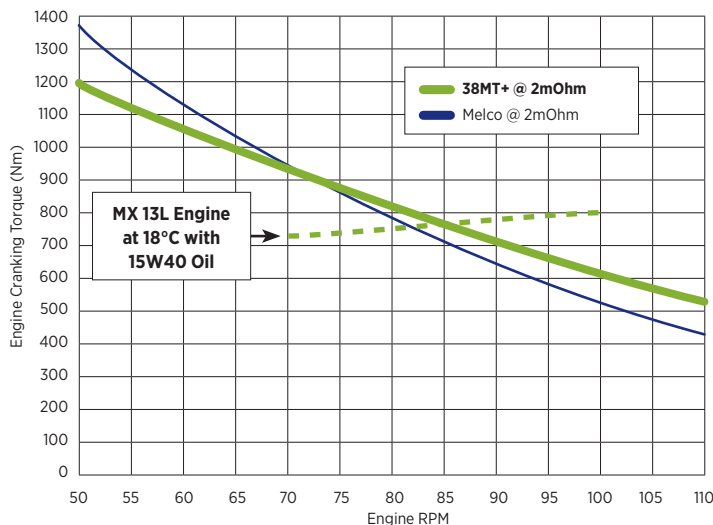

Cranks up to 4% faster than the competition

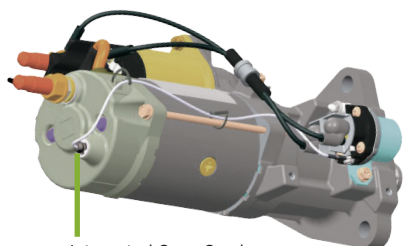

Integrated Over-Crank Protection (IOCP)

Starter Model	OCP	Faster Cranking	Weight
Delco Remy 38MT+	Optional	82 Engine RPM	28.44 lbs/12.9kg
Melco	No	79 Engine RPM	29.32lbs/13.3kg

38MT+™ Heavy Duty Gear Reduction Starter

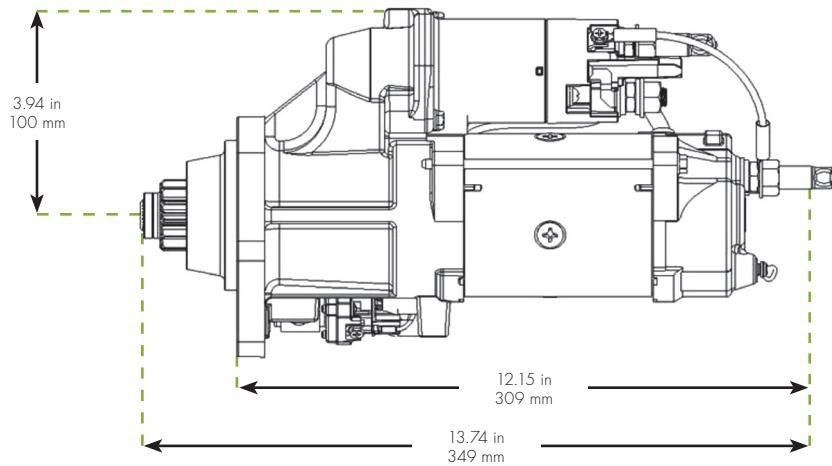

SPECIFICATIONS

Engine Size	up to 13 liter
Rotation	Clockwise
Mounting	SAE #3
Pinion Data	12 Tooth, Mod 3-metric
Output	4.3kW peak at 12V
Weight	12.9 kg/28.44 lbs
Diameter	100 mm/3.94 inches
Heavy Duty Drive	Electrical Soft-Start, Engagement System, Overrunning Clutch

38MT+ designed to fit MX 11 and 13 liter engines

OEM	Engine	Non-OCP 38MT+	Integrated OCP 38MT+	Teeth/Pinion/Pitch	Melco
PACCAR	MX 11/13	8200977	8201084	12 Tooth, Mod 3 Metric	D61-1003-001 D61-6002-011 M009T72578 M9T72578 PC2578 1847916

Tech Support 800-372-3555

If you need assistance with part number identification or electrical system troubleshooting, we're here to help.

delcoremy.com



BorgWarner Inc.
600 Corporation Drive
Pendleton, IN 46064 USA
For Customer Service or Technical Assistance call 1-800-372-3555

Delco Remy is a registered trademark of General Motors Corporation licensed to BorgWarner PDS (Anderson) L.L.C. | C11142 | 12-16